

Acre Multi-Tech Reader Installation Guide

Included Parts:

- Reader, Backplate, Wall Plate
- #6 Machine Screws – QTY 2
- #6 Self Tapping Screws – QTY 2
- #4-40 Phillips Screw
- #4-40 Pin-in-Torx Screw

Tools Needed (Not Supplied):

- Phillips Screwdriver
- 1" (25mm), 1/8" Drill bits
- T8 Security Torx Bit (optional for increased tamper detection)
- #6-32 Tap if required

Wiring Connections	
Red	Power In
Black	Ground
Shield	Shield Ground
Green	Wiegand: Data 0 OSDP: RS485A(+)
White	Wiegand: Data 1 OSDP: RS485B(-)
Yellow*	Beeper Control
Brown*	Tamper Out
Blue*	Green LED Control
Orange*	Red LED Control

*These wires are only used in Wiegand mode
 **All wiring methods used shall be in accordance with the National Electrical Code, ANSI/NFPA 70
 Readers must be powered by a compatible UL Listed, power limited, access control panel rated 5 – 16 VDC.

- Install Metal Wall Plate to Mullion/Single Gang box.
 - Use the provided #6 screws.
- Wire the Cable to the Control Panel.
- Attach the Reader to the Wall Plate and Install the Reader Screw.
 - Follow steps 1 through 3 below to ensure proper alignment. Install either the #4-40 screw or Pin-in-Torx screw at bottom.

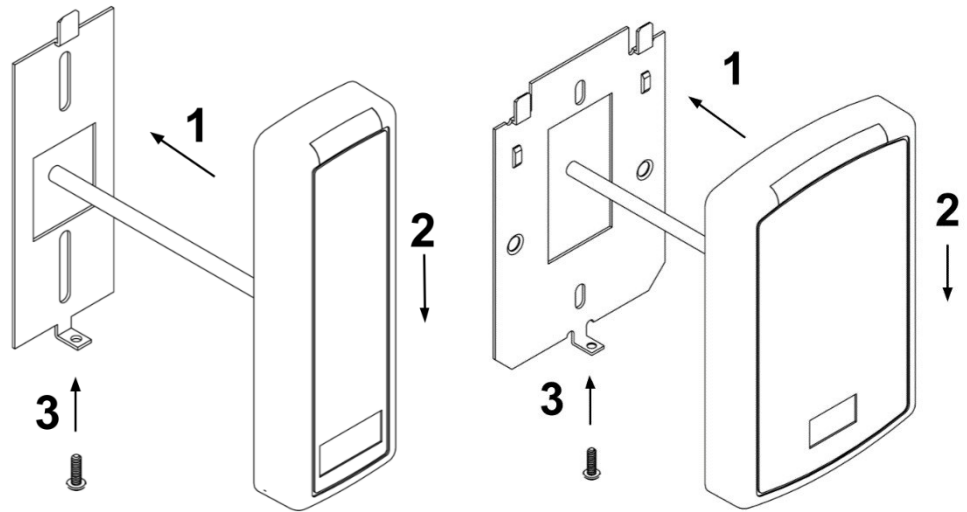

	Mullion Model - AT10	Single Gang Model - AT20	Keypad Model - AT25
RF TECHNOLOGIES	Part Number	Part Number	Part Number
13.56 MHz	AT10-2WS*	AT20-2WS*	AT25-2WS*
125 kHz & 13.56 MHz	AT10-3WS*	AT20-3WS*	AT25-3WS*
13.56 MHz & Mobile	AT10-6WS	AT20-6WS	AT25-6WS
125 kHz, 13.56 MHz, & Mobile	AT10-7WS	AT20-7WS	AT25-7WS
CURRENT	105 mA average, 145 mA peak	120 mA average, 170 mA peak	145 mA average, 195 mA peak
VOLTAGE	5-16 VDC		
TEMPERATURE	UL™ tested -35° to 66°C and EN -40° to 70°C and 95% humidity		
CABLE LENGTH	Communication Lines Wiegand: 200 ft/61 m = 22 AWG 300 ft/91m = 20 AWG 500 ft/152m = 18 AWG OSDP RS-485 at 12 VDC and 25°C: 1000 ft/ 305m = 22 AWG Twisted Pair		

*: -2WS and -3WS variants are only sold in North America.

Reader Startup Sequence		
On power up, the multi-tech readers provide a LED and beeper sequence to provide information about the reader type and its communication mode. The first sequence describes the RF technologies built in the reader: First, a LED sequence will indicate the supported RF protocols.		
BLE	High-Frequency	Low-Frequency
Red LED flash	Green LED flash	Amber LED flash
After the above AV sequence identifies the supported RF protocols, the reader will then indicate the supported host communication using beep/flash sequences.		
Wiegand Only	OSDP Only	Auto-Detect
Beep and Blink Red LED once	Beep and Blink Green LED 2 times	Beep and Blink Green LED 4 times

Wiegand Keypad Mode Setup		
Within one minute of reader reset, enter the keypad config code: *88889999. The reader beeps three times, LED flashes green for each beep. Within 2 seconds of entering the keypad config code, press the corresponding key code below for the desired format. The reader then beeps three times, LED flashes green for each beep.		
4-Bit Format	8-Bit Format	26-Bit Format*
*4	*8	#XXX
NOTE: With OSDP communication, the keypad is not configurable at the reader and is controlled through the PACS software.		

Test and Installation Tips:

- Power the reader and verify Reader Startup Sequence.
- Present a valid credential, reader should beep, flash Green, and report the credential to the panel.
- If the Badge is read, but no credential is reported at the panel, verify panel wiring and panel setup.
- By default, the reader will transmit credential and keypad data in Wiegand communication mode.
- The reader is always listening for an incoming OSDP message. If a message is received during this period, the reader will automatically switch to OSDP-only communication mode.
- When connecting the reader to an OSDP panel, connect the green wire to RS485A(TR+), and the white wire to RS485B(TR-).
- In OSDP, the default baud rate is 9600 and starts up at Address 0.
- To return to OSDP Auto-detect mode, see technical notes or contact technical support.
- Only tokens and firmware versions approved by acre security will be supported.

Additional technical and troubleshooting documents can be found by scanning the QR Code below

Performance Levels:

- Destructive Attack: I
- Line Security: I
- Endurance: IV (125 kHz, 13.56 MHz), I (BLE)
- Standby Power: I
- CAN / ULC 60839-11-1: Outdoor Rating Grade 1

Approvals:

EN302291, EN301489, EN300330, IP55, UL294

Patents - US9558377, & US9747738B1

This equipment has been tested and found to comply with the limits for a Class B digital device, pursuant to part 15 of the FCC Rules. These limits are designed to provide reasonable protection against harmful interference in a residential installation. This equipment generates, uses and can radiate radio frequency energy and, if not installed and used in accordance with the instructions, may cause harmful interference to radio communications. However, there is no guarantee that interference will not occur in a particular installation. If this equipment does cause harmful interference to radio or television reception, which can be determined by turning the equipment off and on, the user is encouraged to correct the interference by one or more of the following measures:

- Reorient or relocate the receiving antenna.
- Increase the separation between the equipment and receiver.
- Connect the equipment into an outlet on a circuit different from that to which the receiver is connected.
- Consult the dealer or an experienced radio/TV technician for help.

This telecommunication equipment conforms to NTC technical requirement. This device contains licence-exempt transmitter(s)/ receiver(s) that comply with Innovation, Science and Economic Development Canada's licence-exempt RSS(s). Operation is subject to the following two conditions: 1. This device may not cause interference. 2. This device must accept any interference, including interference that may cause undesired operation of the device. L'émetteur/récepteur exempt de licence contenu dans le présent appareil est conforme aux CNR d'Innovation, Sciences et Développement économique Canada applicables aux appareils radio exempts de licence. L'exploitation est autorisée aux deux conditions suivantes: 1. L'appareil ne doit pas produire de brouillage. 2. L'appareil doit accepter tout brouillage radioélectrique subi, même si le brouillage est susceptible d'en compromettre le fonctionnement.

