



## Contact Closure Applications with the CNFE3FX1TX2C[/M] Series

The CNFE3FX1TX2C[/M] Series looks to be a simple contact over Ethernet device, however there are a few things to be considered, based on how the device works.

This document will show a few possible configurations and describe potential limitations or issues.

- Operation “One to One”
- Operation “One to Many”
- Complex setup example with multiple local and remote devices

### Table of content

1.	Operation “One to One”	2
1.1.	Configuration “One to One”	2
2.	Operation “One to Many”	4
2.1.	Configuration “One to Many”	4
3.	Complex Setup (Example)	8

# SUPPORT INFORMATION

## 1. Operation “One to One”

The “One to One” mode is the simplest of all modes, where only two devices are linked and every individual input is linked to one individual output

### Device to Device (8 CH Simplex)

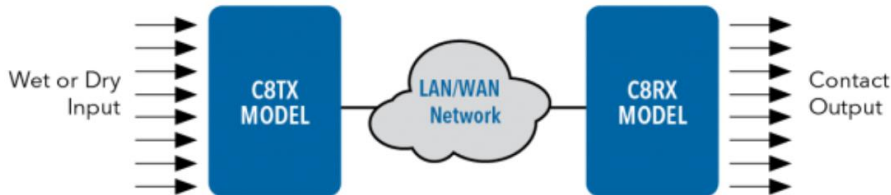

### Device to Device (4 CH Duplex)



## 1.1. Configuration “One to One”

### 1.1.1 Network Settings

**Network Configuration** →

MAC Address: 00:22:3b:40:12:25  
Host Name: CNFE3FX1TX2C4DX  
 Enable DHCP  
IP Address: 192.168.10.12  
Gateway: 192.168.10.254  
Subnet Mask: 255.255.255.0  
Primary DNS: 192.168.10.254  
Secondary DNS: 0.0.0.0  
Apply Help

➔ Give each unit a unique IP address

# SUPPORT INFORMATION

## 1.1.2 Input settings

**IN Contact Ethernet Link** →

Input Contact Config			
<input type="checkbox"/> One to One enable	Status: Not Connected		
Remote Output IP: 192.168.10.11	Port No.: 6565		
Selected Input Contacts			
<input type="checkbox"/> 1	<input type="checkbox"/> 2	<input type="checkbox"/> 3	<input type="checkbox"/> 4

- Enable "One to One"
- Define IP of remote output device
- Port settings don't need to be touched, unless the local network environment requires different settings.
- Activate the Inputs that should be used

## 1.1.3 Output Settings

**Out Contact Ethernet Link** →

Output Contact Config	
<input type="checkbox"/> Retain remote data	
<input type="checkbox"/> One to One enable	Status: Not Connected
Remote Input IP: 192.168.10.1	Port No.: 6565

- Enable "One to One"
- Define IP of remote input device
- Port settings don't need to be touched, unless the local network environment requires different settings.
- Optional setting: Retain remote data: Will save the last known transmitted value upon loss of connection with remote sensor. Otherwise, the open state will return after a timeout period.

## 2. Operation “One to Many”

The “One to Many” mode consists of one central unit and multiple edge units. For example, 8 inputs in the centre and multiple outputs at the remote locations – or vice versa.

### One to Many

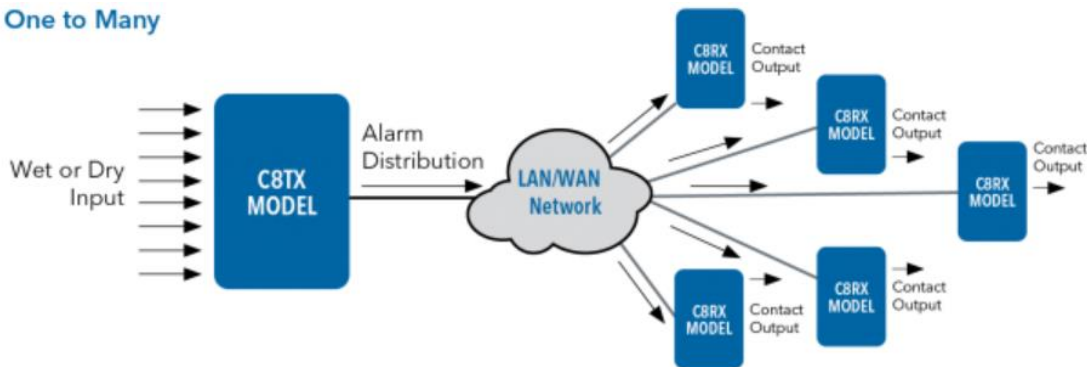

### Many Devices to One Device

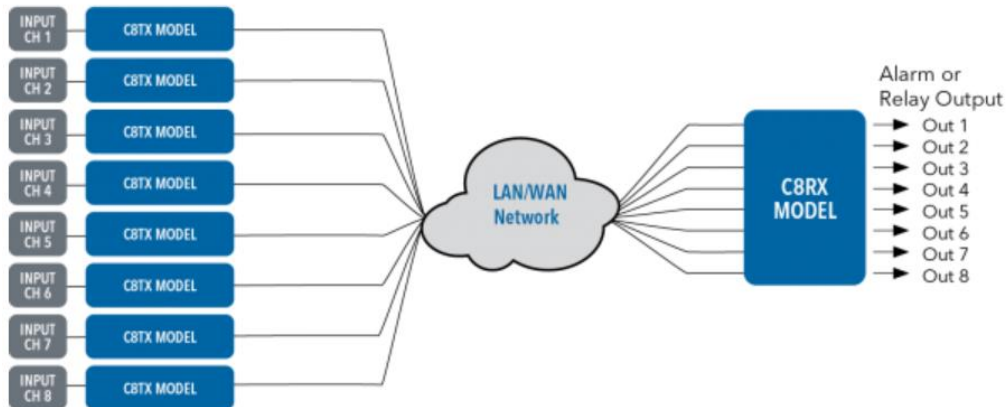

### 2.1. Configuration “One to Many”

#### 2.1.1 Network configuration

See Chapter 1.1.1

In addition, make sure your network allows multicast traffic to pass.

## 2.1.2 Central unit configuration

The central unit can either be a pure in- or output device or both.

### Input configuration

**Selected Input Contacts**

<input type="checkbox"/> 1	<input type="checkbox"/> 2	<input type="checkbox"/> 3	<input type="checkbox"/> 4
<input type="checkbox"/> One to Many enable		Status: Not Connected	
Multicast Group: 235.168.10.1		Port No.: 6565	

Apply Help

- ➔ Select the inputs needed
- ➔ Enable “One to Many”
- ➔ Define Multicast group. Usually the defined group can be kept – it might needs changing based on local network addressing polices or for the “Many to Many” mode, see Chapter 3.
- ➔ Port settings don’t need to be touched, unless the local network environment requires different settings.

### Output configuration

**Output Contact Config**

<input type="checkbox"/> Retain remote data	
<input type="checkbox"/> One to One enable	Status: Not Connected
Remote Input IP: 192.168.10.1	Port No.: 6565
<input type="checkbox"/> One to Many enable	Status: Not Connected
Multicast Group: 235.168.10.1	Port No.: 6565

Apply Help

- ➔ Enable “One to Many”
- ➔ Define Multicast group. Usually the defined group can be kept – it might needs changing based on local network addressing polices or for the “Complex Setup” in Chapter 3.

## 2.1.3 Remote unit configuration

The edge units will connect to the central units. If you use an 8-channel output in the centre, each edge location will need a 8 channel input unit, even if only one input is required at the remote location.

### Input configuration

- ➔ Select the inputs needed. If the same input is enabled on multiple locations all of those can fire the respective output on the central unit.
- ➔ Enable “On to Many”
- ➔ Define Multicast group. Make sure all involved units (Centre and Edge) are part of the same group.
- ➔ Port settings don’t need to be touched, unless the local network environment requires different settings.

### Output Link configuration

- ➔ Enable “One to Many”
- ➔ Define Multicast group. Usually the defined group can be kept – it might needs changing based on local network addressing polices or for the “Complex Setup”in Chapter 3.

# SUPPORT INFORMATION

## 2.1.4 Example (central inputs)

Each input will trigger the respective output on the edge units

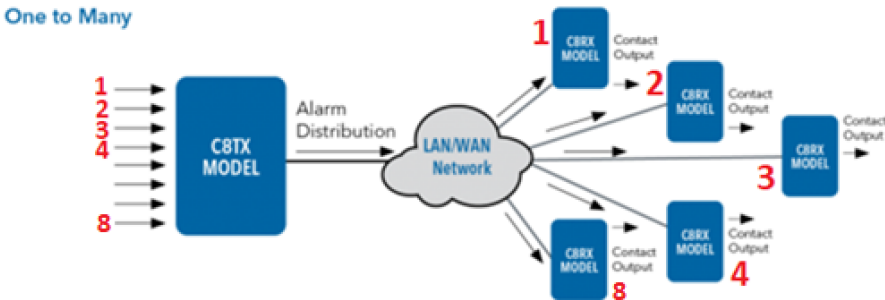

## 2.1.5 Example (central outputs)

Each remote input will trigger the respective central output

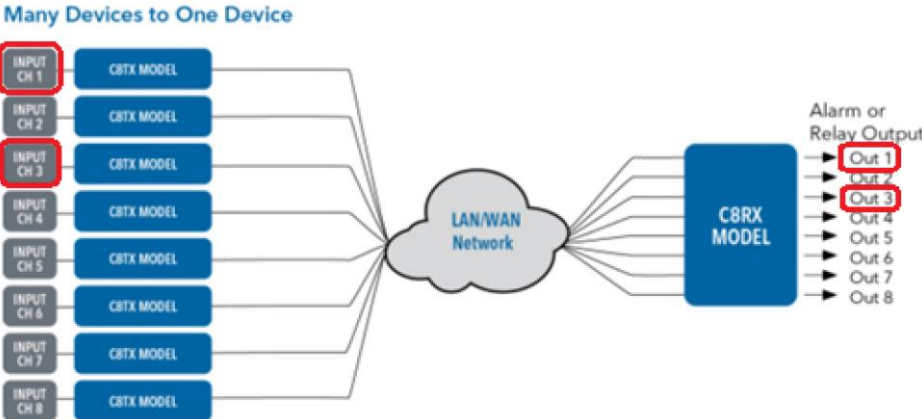

## 3. Complex Setup (Example)

The following example is based on a pre-engineering request. It will show a more complex setup combining different units together incl. multiple multicast groups.

**Setup:** The CNFE3FX1TX2C[/M] Series was used to connect the SPC Panel to multiple remote devices via I/O.

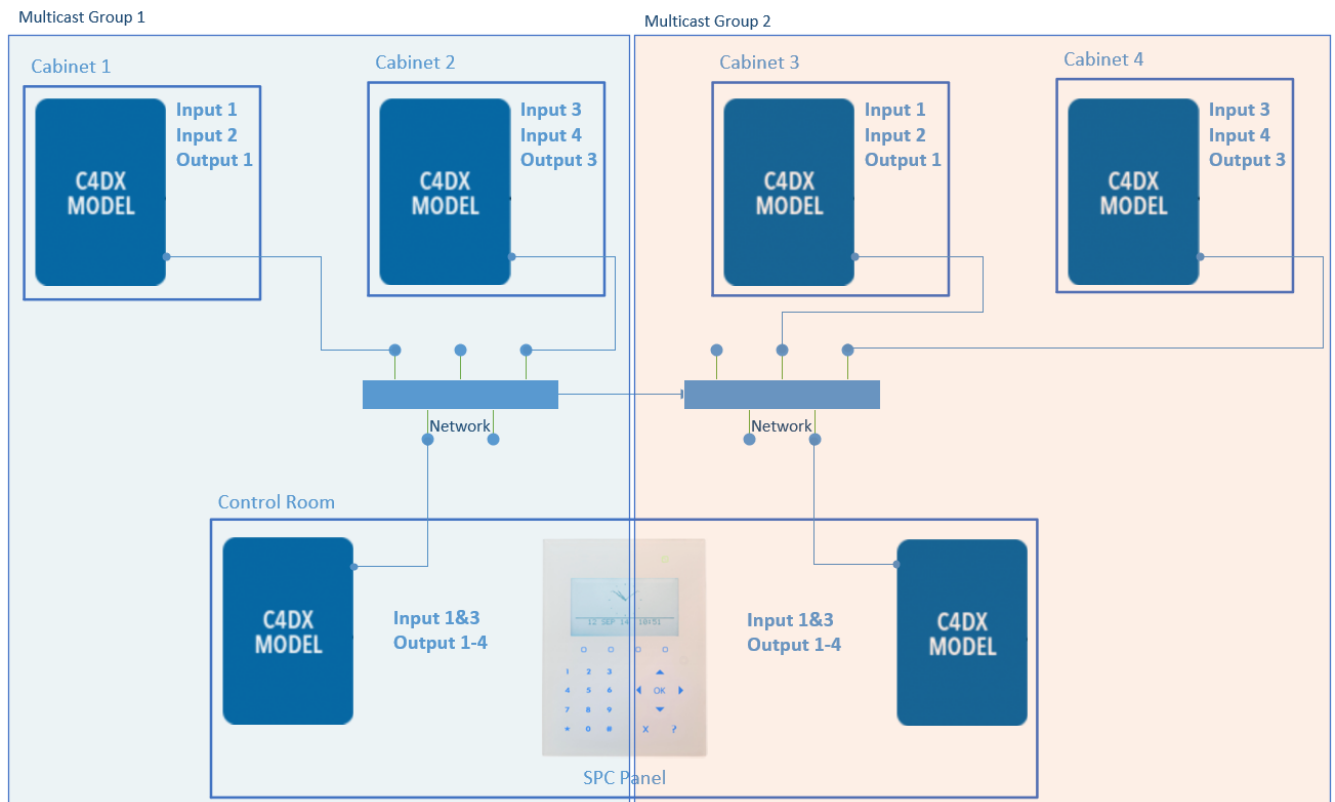

### Remarks & Considerations

- ➔ Operation in “One to many” mode, means that if input 1 is triggered in the control centre, the output 1 will fire in both cabinets, because they are part of the same multicast group!
- ➔ Output 2 must be Output 3 to avoid trigger from Input 2 in cabinet 1 (Inputs and Outputs on the same unit do not trigger each other!)
- ➔ This setup can be replicated X times, each setup needs a unique multicast address to avoid conflicts!

# SUPPORT INFORMATION



If you have any questions, please contact our Technical Competence Centre.  
Contact details can be found on our website.