

INPUT I/O

Configuration for input I/O

MIN I/MAX	I/O	MIN I/MAX	I/O	MIN I/MAX	I/O	MIN I/MAX	I/O
3	4	3	4	3	4	3	4
Signal On / Off Only flash		Signal On / Off Flash and ringing beeps Low volume		Signal On / Off Flash and ringing beeps Strong volume		Input On / Off As remote Separate for flash	

The signal set ON or OFF of the alarm system triggers a series of short beeps and the flashing, when the blocking voltage of 12V is switched to 0VDC. When the blocking voltage is back, the SIRUS generates a new series of beeps with longer flashings this time to distinguish the two states.

For this function, SIRUS can choose between two levels of audible beeps (S3.3) or even deactivate the audible beeps (S3.4) and have only the flashing.

It is also possible to configure this input to order the flash separately.

Use a screwdriver to position the 4 interrupters of configuration of the siren.

TECHNICAL DATA

Direct voltage :	From 9 to 15 VDC
Voltage on +12V CHR :	From 12,0 to 14,5 VDC
Output voltage on +BAT :	13.8 VDC (+/-0.2 Vdc)
Residual ripple allowed :	250mV
Consumption in standby :	5 mA
Autonomy on internal battery :	72 hours
Length of alarm :	OUT : 180 seconds / INT : 31 minutes
Consumption in alarm & Sound power :	OUT MAX : 1.6A 109 dB at 1m OUT MIN : 0.8A 100 dB at 1m IND MAX : 1.6A 113 dB at 1m IND MIN : 0.8A 110 dB at 1m
Consumption in only alarm light :	20 mA
Order voltage « SIR » and « I / O » :	From 9 to 16 VDC (0,1mA)
Triggering voltage « SIR » and « I / O » :	Below 3 VDC
Reset voltage « SIR » and « I / O » :	More than 9 VDC
Cover :	Polycarbonate / class V0 / anti-UV
Degree of protection :	IP 43 IK 08
Environment :	Class IV – General outdoor
Operating temperature :	-25°C to +70°C
Cable type for the connection :	3 pairs cable rigid : Ø >= 0,5mm flexible : Ø >= 0,2mm
Type of backup batteries :	12V 2.1Ah YUASA NP2.1-12FR 12V 2.1Ah YUCELL Y2.1-12FR 12V 2.0Ah POWERSONIC PS 1220 V0 12V 2.2Ah ELECKSON BEL120022 12V 2.3Ah ACD ST20 12V 2.3Ah SUNLIGHT SP 12-2.1V0

Electromagnetic compatibility : in accordance with the norms NF EN 50130-4 and NF EN 55022
Electric security : in accordance with the norm EN 60950 ed.. Oct. 2000

Altec

NOTINS0UK000018-V1.05

INSTALLATION GUIDE

Outdoor siren self-powered

Made in FRANCE



SIRUS



Housing in
POLYCARBONATE



LEDs

Non contractual photo

SIRUS is admitted to NF and A2P « 3 shields » in accordance with norms NFC48-265 and NFC48-266 and with the reference of the certification NF324-H58
Certificat n°: 3230400691 – Manufacturing Unit : N° 122 P2

CNPP Certification (centre national de prévention et de protection):
<http://www.cnpp.com>

AFNOR Certification :
<http://www.marque-nf.com>

According to the continuous improvement of our products, the information contained in this guide may be subject to change without notice. ATLS may not be held liable for any errors contained in this document, nor incidental or consequential damages relating to the supply, the quality or use of this document.

Certificate number INCERT : B-712-0002

The products of the range ALTEC are designed and made in France by the company ATLS
SIRUS and ALTEC are registered trademark of ATLS

INTRODUCTION

You have just bought the outdoor siren self-powered **SIRUS** of the range **ALTEC**. Many thanks.

Designed to last, SIRUS comes in a moulded case made in Polycarbonate with a flammability class V0 with UV resistance to the test of time.

SIRUS includes an alarm light with LED technology ultra high brightness, which in addition to a high resistance to vibration and extreme temperatures offers a lifetime much superior to traditional solutions

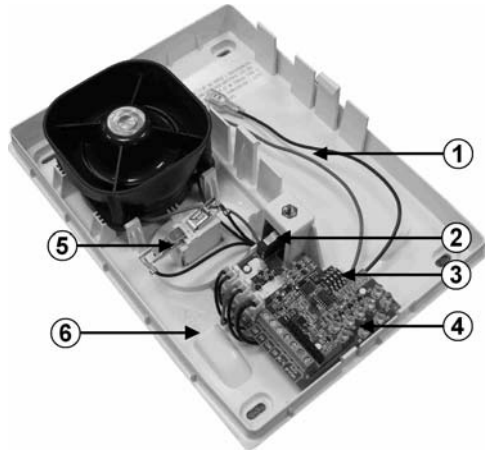

- 1- Support for backup battery
- 2- Opening tamper
- 3- Interrupters of configuration
- 4- Flash with leds!!! **WARNING!!!** Leds are type high brightness. Do not face.
- 5- Sensor for removal tamper
- 6- Running cable

SIRUS has a double load regulation for the internal battery:

- **Regulation of charging current to 100 mA**, sufficient to charge the internal battery normally. In alarm, only the internal battery is required. This effectively protects the charger of the panel when several sirens are powered by it.

- **Regulation of charging current to 13.8 Vdc**: Even if the charging voltage delivered by the panel is not high enough, SIRUS amplifies it to provide to the battery a charging voltage of 13.8 Vdc to warranty a perfect load.

WIRING

- Before wiring the auto-protection, make sure that the circuit does not exceed 60VDC/0,1A.
- The supply terminal « +12V DIR » can be used to provide the required current to operate the SIRUS even in the absence or failure of the backup battery. However, there should be provided a source of high capacity and protected against over current that can be caused by a defective backup battery.
- The power of SIRUS through the terminal « +12V CHR » is the recommended method because the backup battery has a constant load with a current limit at 100mA and a voltage regulator at 13.8Vdc. In alarm, only the internal battery is sought and protects effectively the charger of the panel..
- If the equipment that drives the SIRUS is not the one which provides the current, you have to connect the terminal « 0V » to this equipment to obtain a common reference.
- The blocking or the resetting of the SIRUS is driven by a positive control voltage of 9 to 16V continuous on the input « SIR ».
- The terminal « I / O » allows the placing of signs OBN or OFF of the alarm system by a blocking voltage between 9 and 16VDC.

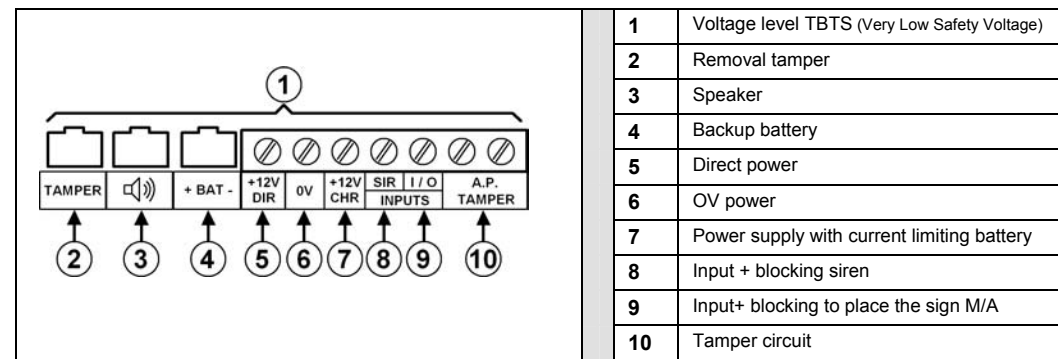

All the connections are Very Low Safety Voltage in terms of the norm EN 60950. The SIRUS electric power must be supplied by a limited power source.

OPERATION

Interrupters of configuration

Position	Interrupter 1	Interrupter 2	Interrupter 3	Interrupter 4
Function	<i>Ringig</i> (terminal SIR)		<i>Signalling ON/OFF</i> (terminal I / O)	
Option	Modulation type	Level of ringing	Volume of the beeps signalling M/A (ON/OFF)	Beeps signalling M/A(ON/OFF)
ON	Internal	MIN	MIN	Audible and luminous signalling
OFF	External	MAX	MAX	Only liminous signalling

INPUT SIR

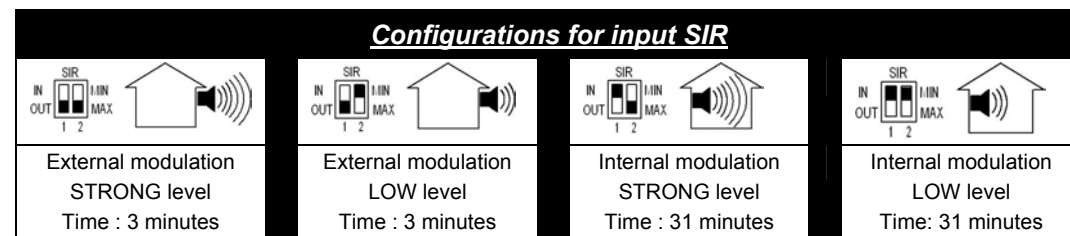

A positive continuous voltage 9 to 16V on terminal « SIR » allows blocking or resetting the SIRUS. When this voltage disappears, the ringing alarm is activated during 3 minutes in external modulation and 31 minutes in internal modulation (S3.1) while the flash is activated until the return of the blocking voltage. **WARNING: only the external modulation is allowed in outdoor use.** Note that during the power up, SIRUS does not trigger even if the blocking voltage is absent. First, all must be armed by applying the blocking signal for at least 1 second. The sound power level of modulation can be reduced (S3.2).

DESTRUCTION OF THE PRODUCT



As required by the WEEE (Waste Electrical and Electronic Equipment), electrical and electronic equipment must be disposed separately from normal household garbage to promote the reuse, recycling and other forms of recovery, as well as limit the amount of waste requiring disposal and thereby reduce the landfill. When disposing of such products, please follow the instructions of local authorities and / or check with your dealer when purchasing a new product.

DESTRUCTION OF THE BATTERIES

SIRUS may have been installed with a battery or a backup battery backup. Do not dispose of batteries in your trash, it is forbidden to cremate, bury them or throw them into landfills. Dispose batteries according to the current laws and regulations. Please contact relevant authorities for further information on the arrangements put in place in your region to collect, to recycle and to dispose of used batteries.

INSTALLATION

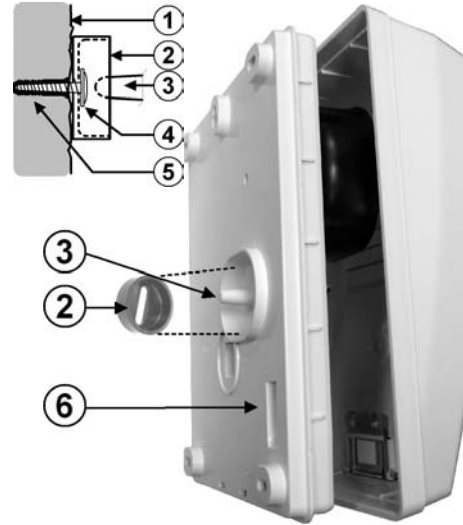

SIRUS is fixed on a vertical wall and flat surface greater than that of its box, leaving at least 2cm on each side. Drill the mounting holes according to the drilling template, and then attach first the plastic plug-shaped on the wall. Then, place the chassis of the SIRUS taking care to place the sensor monitoring breakout inside the plastic cover. This system requires no adjustment.

It is imperative to test and verify the proper functioning of the audible, visual and auto-protection after the installation.

It is strongly recommended to check periodically the proper tightening of connections and the status of the backup battery and replace if necessary.

- | | |
|-----------------|-------------------|
| 1- WALL | 2- TAMPER PLUG |
| 3- TAMPERSENSOR | 4- SCREW |
| 5- INSERT | 6- RUNNING CABLES |

SAFETY INSTRUCTIONS

- Avoid looking directly at the LEDs in operation.
- During the tests, wear a hearing protective helmet or hold you at a reasonable distance of the SIRUS.
- Do not perform any operation on SIREX in stormy weather.
- Use only the type of the batteries indicated on the specifications table

WARRANTY



ATLS provides a guarantee of 5 years from the date of the manufacture.

The year and month of manufacture appear on the label serial number placed inside the device.

The warranty does not cover non-functional damage such as scratches, broken by a fall or shock or degradation caused by abnormal use. The guarantee applies only to cards and electronic assemblies and does not cover damage caused by natural or artificial surges. The guarantee applies only if the electronic part has not been dismantled, disturbed or transformed.

The warranty is strictly limited to repair or exchange parts that we found defective. Return costs are still borne by the sender.

The detention of equipment under warranty won't give rise to any compensation for any reason whatsoever.

The responsibility of A.T.L.S. is limited to the repair of products and do not extend to the consequences of their use, their implementation or their non-functioning.

DRILLING TEMPLATE Sirius (scale 1 : 1)

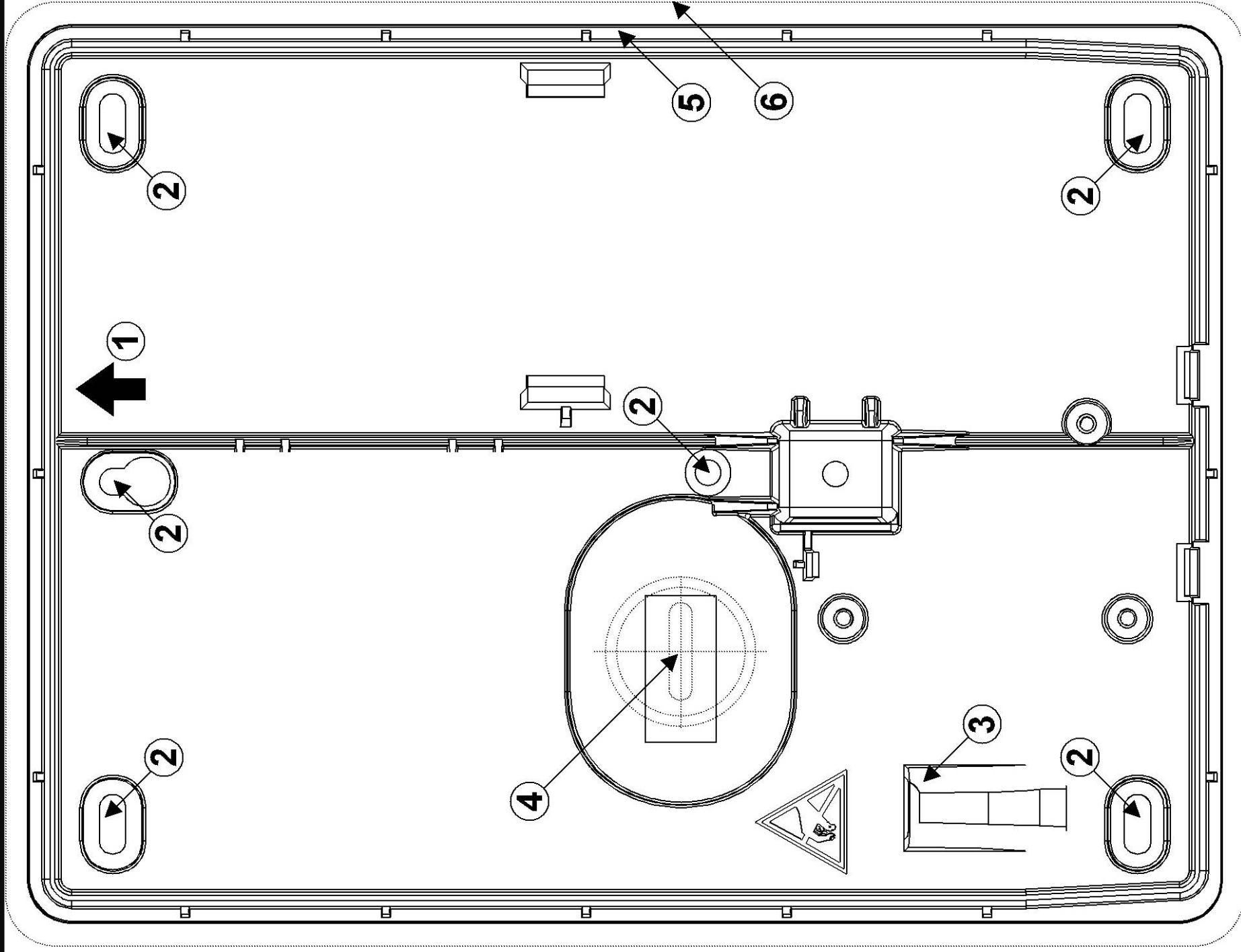

WARNING : Take precautions to avoid electrostatic discharge during installation or maintenance of the siren.

- 1- Top of the box
- 2- Mounting holes(X5)
- 3- Running cables
- 4- Drilling axis for the plastic cover of the tamper
- 5- Chassis
- 6- Cover

