

# PA2EW

Hold up device

VANDERBILT



## Key Features include:

- Visual confirmation of operation
- Momentary push buttons
- Operation of both buttons to activate
- Gold plated contacts for long term, reliable operation
- Tamper for cover removal
- Key resettable, when activated
- Robust construction
- Flexible configuration options
- Silent operation of micro-switch
- PD6662:2010 compliant

# PA2EW

Hold Up Device

VANDERBILT

## Internal & external layout details

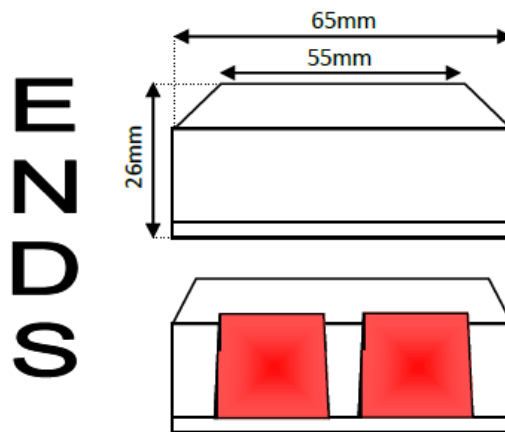
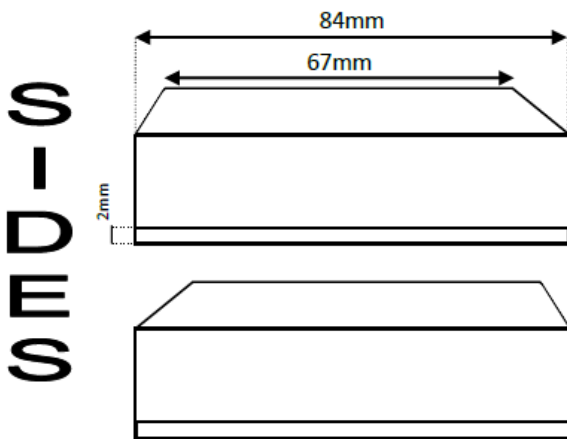
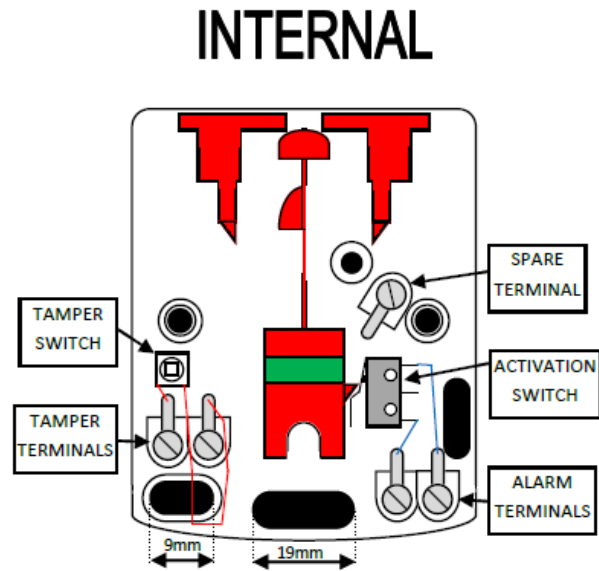
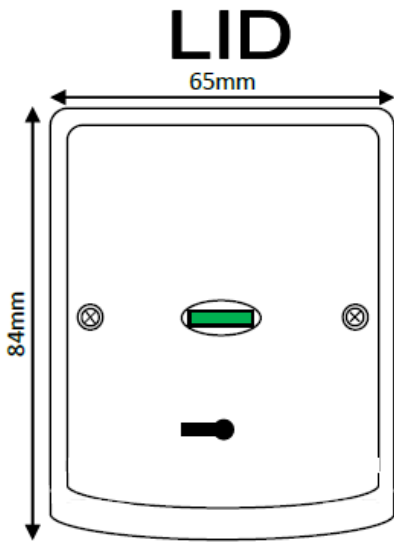

VANDERBILT

# PA2EW

Hold Up Device

VANDERBILT

| ■ Technical Specifications |   |
|----------------------------|---|
| Tamper contact             | 1 x N/C tactile switch, (tamper rear via wire link) |
| Alarm contacts             | 1 x NC micro-switch                                 |
| Housing                    |   |
| – Colour                   | White   |
| – Material                 | ABS   |
| Switching voltage          |   |
| – Alarm contacts           | 15V DC/500mA  |
| – Tamper contacts          | 15V DC/50mA   |
| Cable connection           | Screw terminals                                     |
| Cable access               | Knockouts (1 x end, 1 x back & 2 x sides)           |
| Visual indication          | Red LED alar, GREEN normal                          |
| Reset                      | Latched, reset vis key (provided)                   |
| Environmental              |   |
| – Operating temperature    | -40 ... +50°C                                       |
| – Environmental class      | II  |
| – Housing protection       | IP31  |
| – Humidity                 | 85%   |
| Dimensions (D x W x H)     | 26 x 64 84mm  |

## ■ Ordering information

| Type  | Art.-No.         | Description       | Weight   |
|-------|------------------|-------------------|----------|
| PA2EW | N54543-Z151-A100 | Hold up button G3 | 0.090 Kg |