

DESCRIPTION

PSV 2435-12 is an up-to date power supply unit with battery backup compliant with EN standards. Unit provides all features required by EN 50131-6:2008, security grade 3.

Distinctive and unique feature of PSV 2435-12 is invented by Alarmtech ViP mode – Voltage-in-Parallel. Power supply units with ViP feature can be connected in parallel both (+) and (-) on one common power bus without a need of additional synchronization. Connected units will share load on a bus. ViP feature can be used to build distributed and redundant power systems. It can be also used to compensate voltage drops on a bus by placing power supply units in distant bus sections.

Power conversion is based on high frequency SMPS regulator providing high conversion efficiency. Low losses inside unit preserve batteries from overheating shortening battery life time. Computerized battery recharging circuit works in constant potential – limited current mode – the best mode to provide the longest possible battery life time.

Power unit is equipped with built-in diagnostic system detecting and signalling mains failure, different battery failures including end-of-life warning, output faults like low voltage or broken fuse.

APPLICATIONS

- Power supply system for 24 V installations
- Distributed power supply systems with built-in redundancy
- Power supply systems for access control, fire and intruder alarm installations

MAIN FEATURES

- Security grade 3 (EN 50131-6:2008)
- Type A – mains supply with rechargeable battery
- Total rated output in grade 3:
 - 0.25 A (30 h in battery mode with 12 Ah batteries)
- Total rated output in grade 2:
 - 0.74 A (12 h in battery mode with 12 Ah batteries)
- Total rated maximal output to installation: 3.0 A
- Battery recharging current – 0.5 A, providing recharging time below 24 h
- Total current capacity of power unit – 27.6V, 3.5 A
- ViP (Voltage-in-Parallel) feature increasing reliability and capacity of power supply systems – power supplies with ViP feature can be connected in parallel to same bus without need for additional synchronization
- Capable to work with pack of two 12 V/12 Ah sealed lead acid batteries
- Short circuit and overload protection
- Detection of no mains supply (EPS fault)
- Detection of different battery faults (APS fault) – not connected, low voltage, high internal resistance
- Detection of low output voltage (OUT fault)
- Detection and LED identification of broken fuses
- Detection of power unit failure
- Deep discharge protection of battery (DDP)
- Remote and local battery testing
- Tamper security provided – case opening and pry-off

BLOCK DIAGRAM

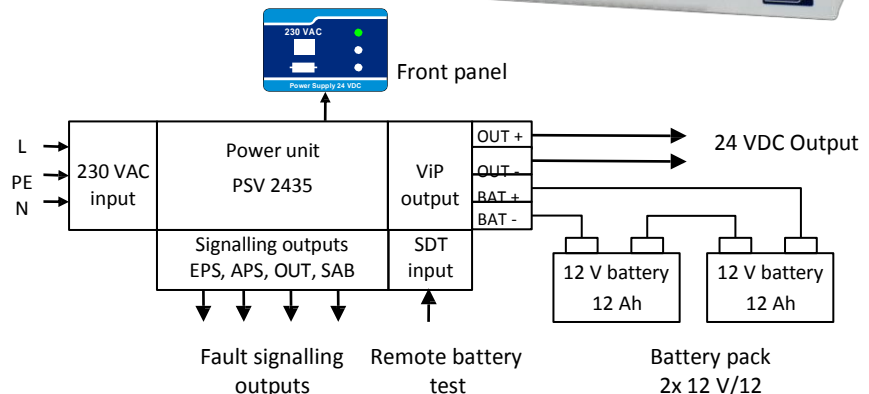

EPS – External Power Supply (mains)
 APS – Alternative Power Source (battery)
 OUT - Output voltage
 SAB – Sabotage
 SDT – Storage Device (battery) Test

1. INSTALLATION

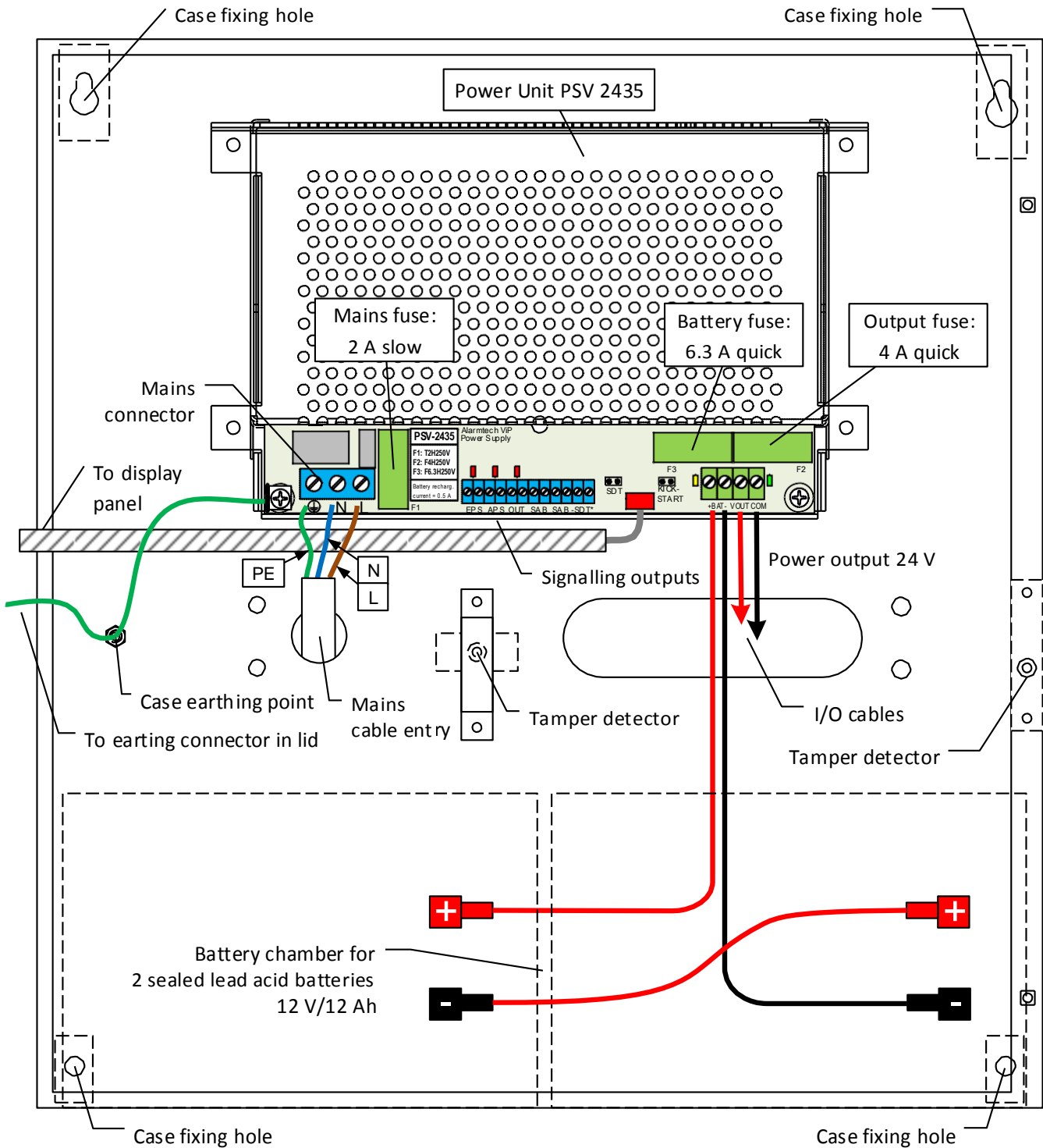

PSV 2435-12 power supply installation and start-up procedure:

- Fix unit in destination place using 4 fixing holes
- Place two sealed lead acid batteries 12 V/ 12 Ah in battery chambers
- Make internal connection in battery pack connecting left battery (-) with right battery (+)
- Make connection between right battery (-) and battery connector using black battery cable connected to BAT-
- Make connection between left battery (+) and battery connector using red battery cable connected to +BAT
- Make appropriate connections between power output and power receivers
- Make required connections between signalling outputs of PSV 2435-12 unit and cooperating units (outputs EPS, APS, OUT, SAB, input -SDT*)
- The socket outlet delivering 230 VAC shall be installed near the power supply unit and shall be easily accessible
- Make sure that cable delivering 230 VAC to power supply is disconnected from mains
- Carry in cable delivering 230 VAC to the unit using separate mains cable entry on the left side and connect it to 230 VAC input of PSV 2435 power unit – make sure that PE cable is connected to PE input
- Switch on mains delivering energy to power supply - PSV 2435-12 unit will start automatically delivering power to the load and monitoring state of PS

2. TECHNICAL DESCRIPTION

2.1 Front panel

Power supply unit is equipped with front panel showing actual general state of unit. Three LED's display shows:

- Green LED: mains voltage present – unit in EPS mode supplied from mains
- Yellow LED: mains voltage missing – unit in APS mode supplied from battery
- Red LED: fault detected – quick visual identification and localisation of failure is possible with help of set of diagnostic LED's in power unit

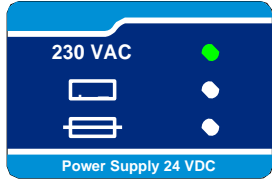

Unit state OK
Supplied from mains
Battery OK
Output OK
No faults reported

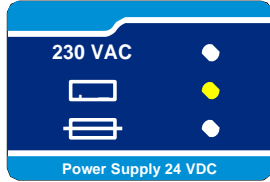

Missing mains
(EPS output triggered)
Supplied from battery
No other faults

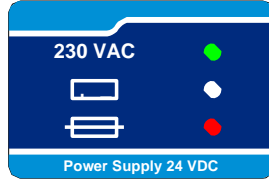

PS supplied from mains
Possible fault detected:
- APS (battery)
- OUT (output)

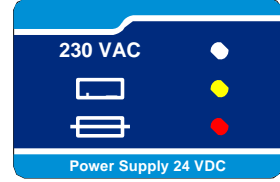

Missing mains
(EPS output triggered)
Supplied from battery
Possible faults detected:
- APS (battery)
- OUT (output)

2.2 Internal state monitoring functions in power units

All monitored states of PS are displayed with help of LED diodes for quick visual identification. The placement of monitoring LED is documented in below placed drawings. The meaning of LED colours is following:

- Green - normal state, OK
- Red - fault detected
- Yellow - informative meaning (neutral)

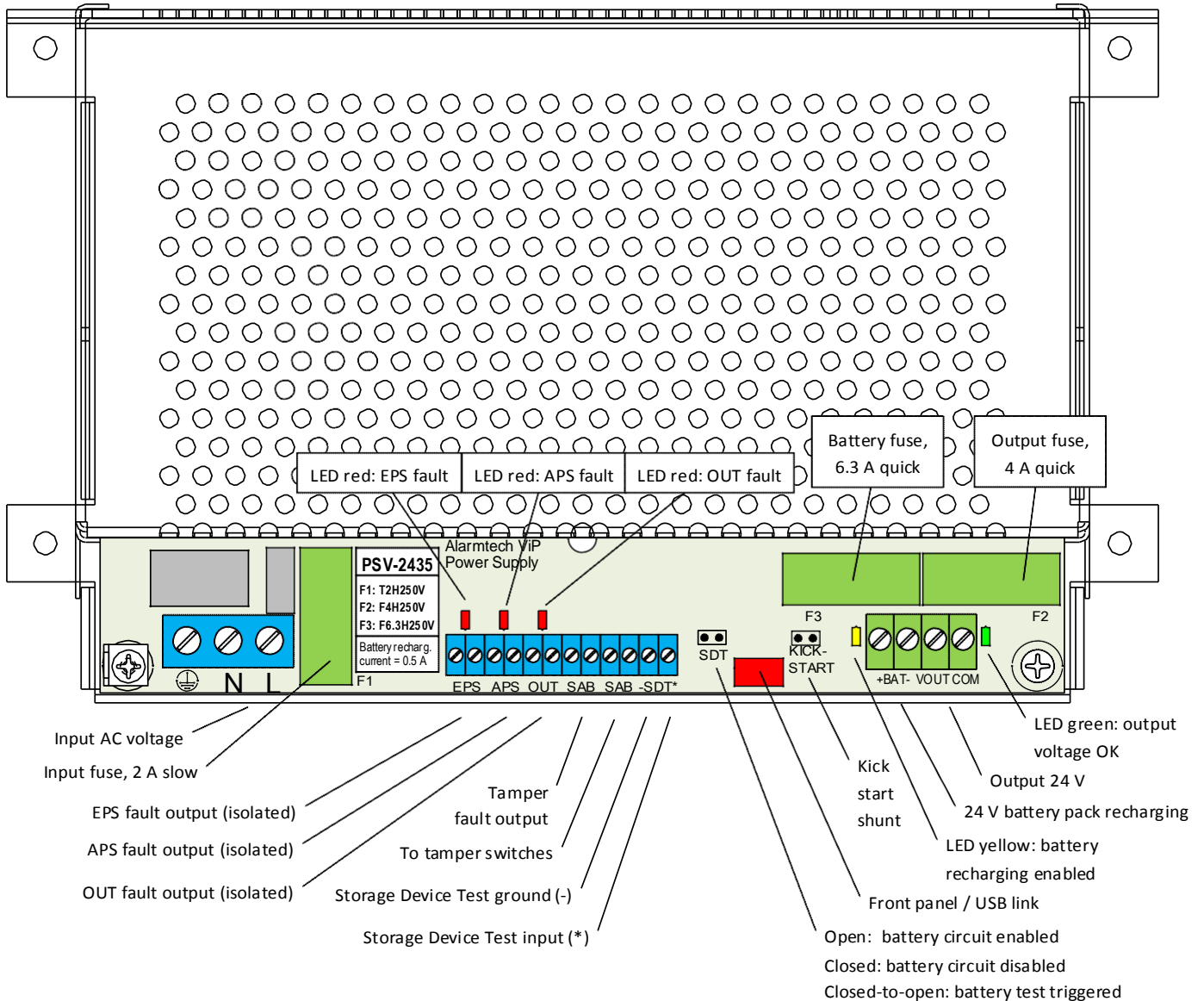

2.3 Jumpers in power units

Power unit is equipped with 2 jumpers placed on PCB:

- Kick-start jumper (default position: open)

Momentary shunt	Kick-start of PS from battery (w/o mains)
Open (default)	Deep Discharge Protection (DDP) of battery enabled
Closed	Deep Discharge Protection (DDP) of battery disabled

- SDT (Storage Device Test) jumper (default position: open)

Momentary shunt	Battery test trigger (30s test of internal battery circuit resistance)
Open (default)	Battery recharging circuit enabled
Closed	Battery recharging circuit disabled

2.4 Input/output terminals

Input / Output	Marking	Description
Mains input with PE	PE, N, L	230 VAC input
Mains failure signalling	EPS	Potential free NC opto-relay output signalling EPS fault
Battery failure signalling	APS	Potential free NC opto-relay output signalling APS fault
Output failure signalling	OUT	Potential free NC opto-relay output signalling OUT fault
Tamper output/input	SAB, SAB	Potential free NC micro-switch connection points
Storage Device Test trigger	-SDT*	Test triggered by momentary shunt between (-) and (*)
Battery pack connection	+BAT-	(+) and (-) terminals for 2x12 V battery pack connection
Power output	VOUT COM	(+) and (-) terminals for power output

3. TECHNICAL SPECIFICATION

Type of Power Supply acc. to EN 50131-6:2008:	type A
Security grade acc. to EN 50131-6:2008:	grade 3
Nominal input voltage rating:	230 VAC, 0.71 A with maximal load, 50 Hz
Nominal output voltage:	27.6 V
Minimum output voltage in battery mode:	20.0 V (in APS mode)
Total rated output in grade 3:	0.25 A (30 h in APS mode with 12 Ah batteries)
Total rated output in grade 2:	0.74 A (12 h in APS mode with 12 Ah batteries)
Total maximal output to installation:	3.0 A
Quiescent current consumed by built-in modules in PS:	0.06 A
Maximum output ripple voltage:	< 50 mVpp
Battery pack type:	Two 12 V/12 Ah sealed lead acid batteries in series
Battery recharging method:	constant potential – limited current
Maximum battery recharging current:	0.5 A
Time to recharge batteries to 80%:	24 h max
Over-voltage protection trigger level:	34.5 V
Battery pack voltage triggering APS fault:	22 V
Battery pack voltage triggering DDP circuit:	19 V (Deep Discharge Protection level)
Output voltage triggering OUTPUT fault:	18 V
Monitoring outputs:	EPS – loss of mains APS – battery pack low voltage, battery failure, disconnected OUT – output voltage low, power unit failure SAB – case tampering
Electrical characteristics of monitoring outputs:	- Opto-isolated semiconductor relay for EPS, APS, OUT - Micro-switch for case tampering
Logical characteristics of monitoring signals:	Closed state – monitored condition not present Open state – monitored condition present
Remote battery test input:	-SDT* - shunt between terminals (-) and (*) triggers 30 s test of internal battery circuit resistance
Remote battery test acknowledgement:	APS output
Local battery test trigger:	SDT jumper, momentary shunt
Automatic battery diagnostics procedure:	executed every 10 h automatically
Operating temperature and humidity range:	-10 °C...+55 °C, RH to 90%, no condensation
Environmental Class acc. to EN 50130-5:1998:	Class II
Weight without batteries:	approx. 3.3 kg
Weight with batteries:	approx. 11.4 kg
Dimensions:	345 x 325 x 130 mm (W x H x D)
Compliance:	