

PRODUCT LINE: Access

DATE: 02.08.2022

PRODUCT: ACCpro-1500/4000

Version: 01

ACTpro Controller Hubbing via RS485



In some situations in ACTpro Installations there may be limited or no TCP/IP connectivity. For instance the IT department may not want to issue additional IP addresses, or there may not be any structured cabling available for expansion to the system.

For these scenarios ACTpro allows you install ACTpro1500/4000 in a Master/Slave Topology. The PC facing Master controller becomes the Hub, and all other controllers the Slave.

Example: If you had an existing 1520/4000 controller already connected on TCP/IP, or if IT were able to provide one network point, then you can hardwire any further controllers using RS485.

Important Note:

Vanderbilt only recommend hubbed controllers as exceptions, and should not be considered for general installation practice.

Whilst a Controller retains its full functionality whether it's a Master or Slave, communication speed and effectiveness is greatly reduced compared to TCP/IP communication.

Downloads can take significantly longer, controllers can intermittently drop offline depending on the cable and installation quality and firmware updates should only be carried out one controller at a time.

Additional Notes:

- OSDP readers **cannot** be used on an ACTpro 1500 that is either Master/Hub or Slave/Hubbed controller.

- The ACTpro1500 Web Server cannot be used when the controller is connected as an RS485 slave.

Table of content

1.	Wiring for RS485	3
1.1.	Example 1 ACTpro1500 as a Master/Hub	3
1.2.	Example 2 ACTpro4000 as a Master/Hub	4
1.3.	RS485 Wiring/limitations	5
2.	Adding Controllers to ACT	5
2.1.	Master/Hub	5
2.2.	Slave 1	7
2.3.	Slave 2	10

1. Wiring for RS485

1.1. Example 1 ACTpro1500 as a Master/Hub

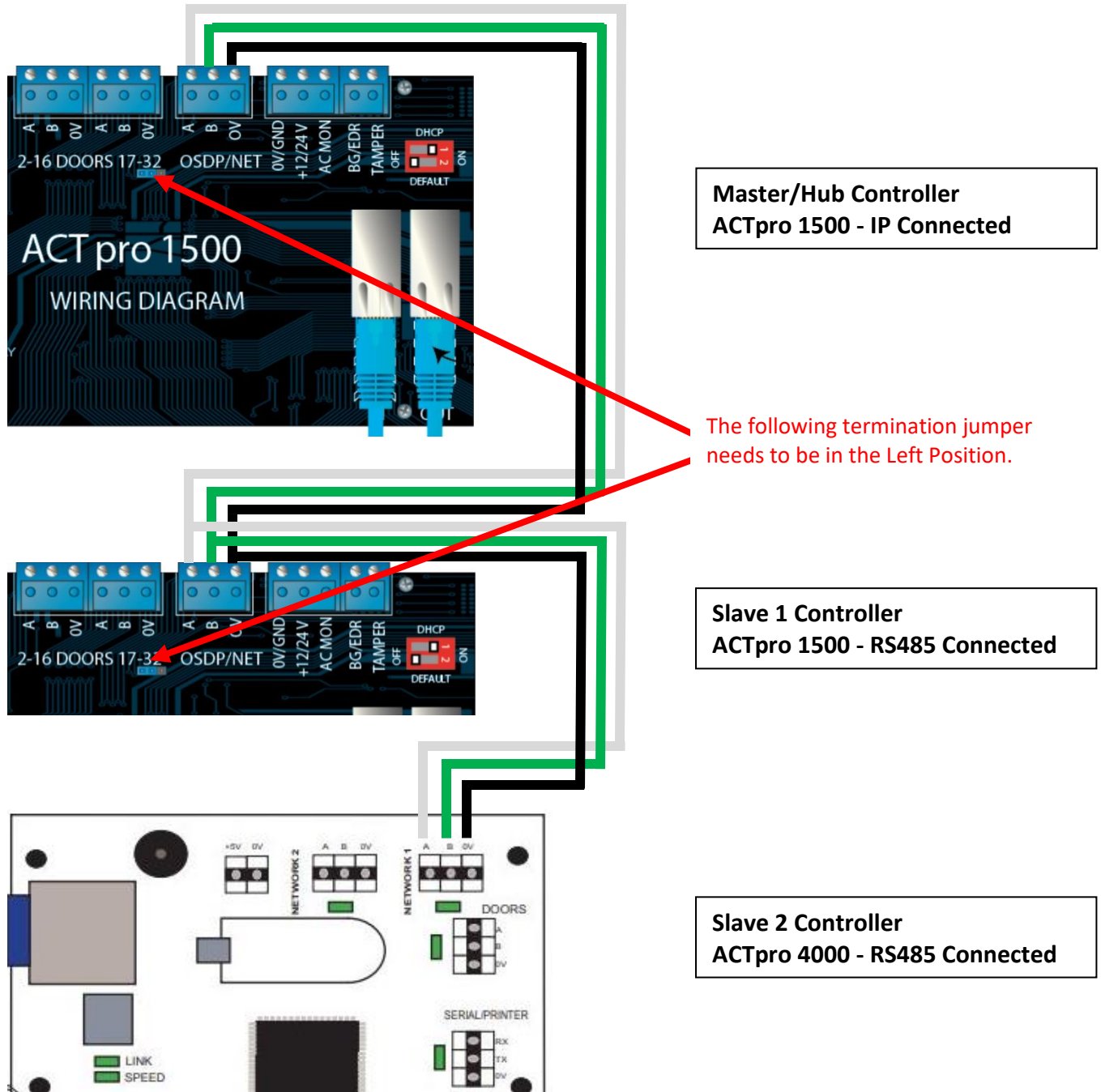

Figure 1

1.2. Example 2 ACTpro4000 as a Master/Hub

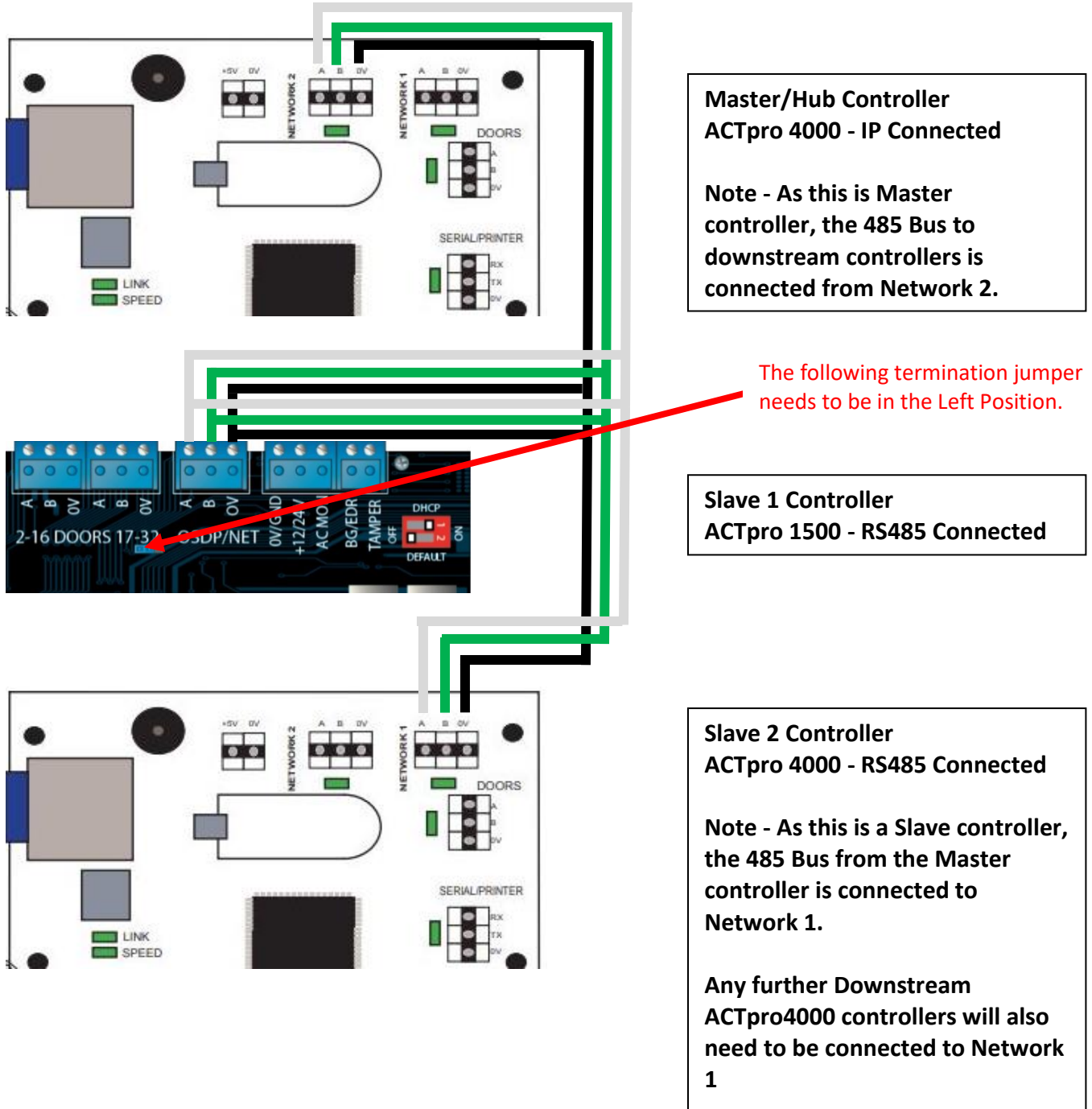

Figure 2

1.3. RS485 Wiring/limitations

As with any RS 485 bus configuration, the following applies.

- Belden 8723 (or equivalent) cable should be used. No CAT5/6 or Alarm Cable.
- Daisy chaining only, no star configuration wiring.
- Up to 1000 meters for the entire length of the Bus from the Master Controller to the final Slave Controller.
- Every device on the bus needs to have a unique RS485 address.
- 0v should be referenced across all devices.

Typically RS485 allows up to 32 devices on the bus, however ACTpro only supports up to 5 when ‘hubbing’ controllers – 1 Master controller, and up to 4 Slave devices.

2. Adding Controllers to ACT

With the controllers physically installed they can be added to ACTpro. This is carried out in ACT Install - Advanced Settings - Controller/Hub Group

This document describes how to program the example shown in Figure 1 (Chapter 1.1); with a ACTpro1500 as the Master and then an ACTpro1500 and an ACTpro4000 as slaves.

2.1. Master/Hub

Click Add Controller.

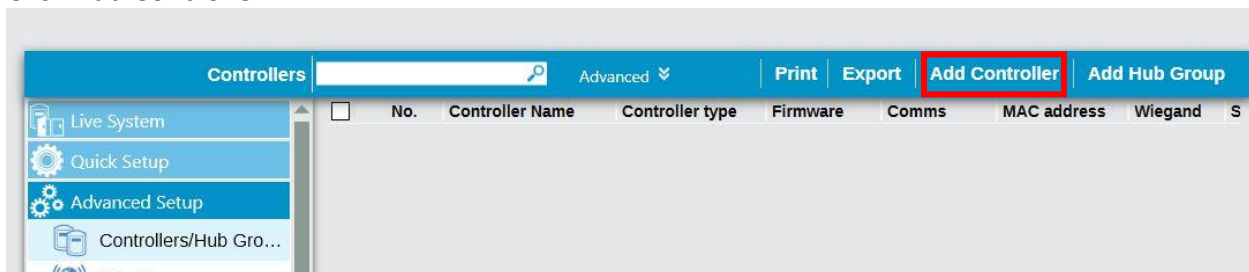

Figure 3

Name the Controller and define the controller type.

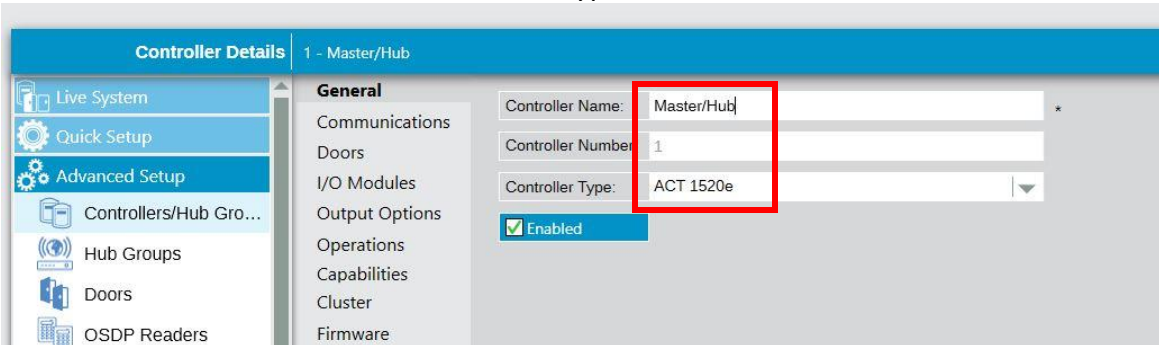

Figure 4

Now go to the communications tab and assign the IP Address of the controller and click save.

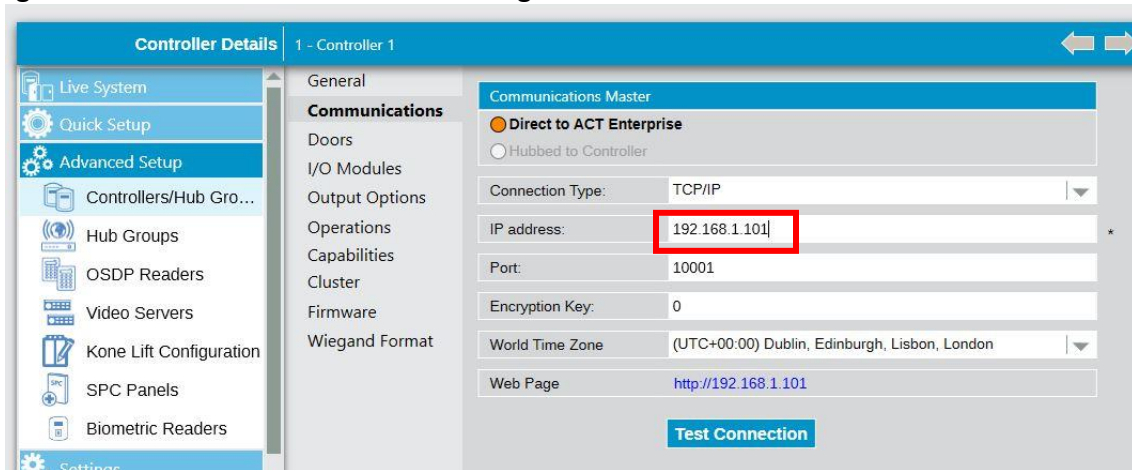
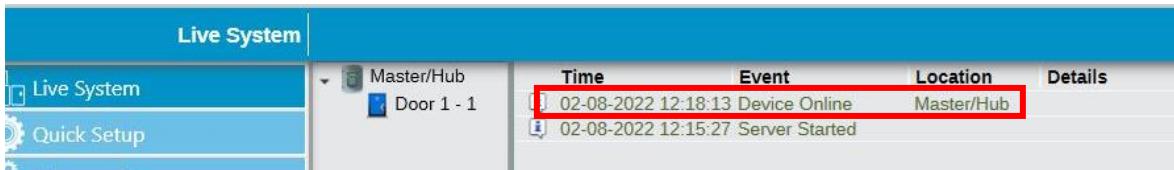
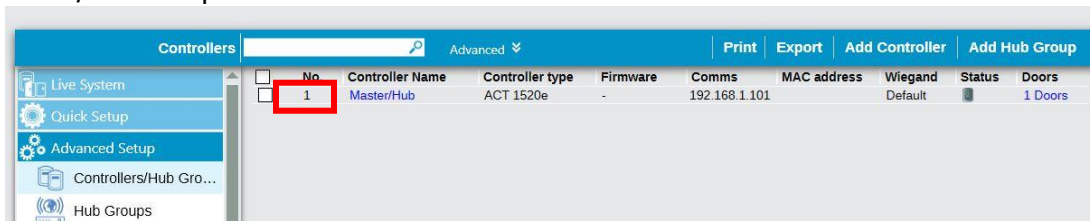

Figure 5

The Master/Hub ACTpro1500 is now online and it has a controller address of 1.



Figures 6 and 7

2.2. Slave 1

Slave 1 is an ACTpro1500. As it's a slave on an RS485 bus it needs to be uniquely addressed. This is one of a few occasions where an ACTpro1500 requires an address other than 1. (For more information on controller addressing see Tech Note on Vanderbilt Download Centre “TCC-2022-019_ACTpro-Controller-Addresses-When-are-they-required?_320_01_EN”)

The slave address must also match its controller number within ACTpro (see figure 8) and its address must be a higher number than the Master/Hub controller. i.e. if the Master/Hub controller is number 5, any slaves must be added to ACTpro with a controller number of 6 upwards and the unique address must match.

As can be seen in Figure 8, ACTpro has assigned Slave 1 as Controller number 2, this is because 2 is the next available address in the Database.

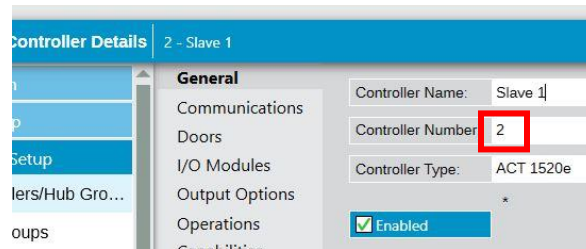

Figure 8

Slave 1 ACTpro1500 must now be given the unique address of 2. This done by logging into the ACTPro1500 web server as installer, clicking on ‘communications’, setting the ‘Controller Address’ and clicking save.

Note: The webserver cannot be used via RS485 connection, so slave controller configuration must initially be carried out on a 1-1 basis (Laptop->Controller).

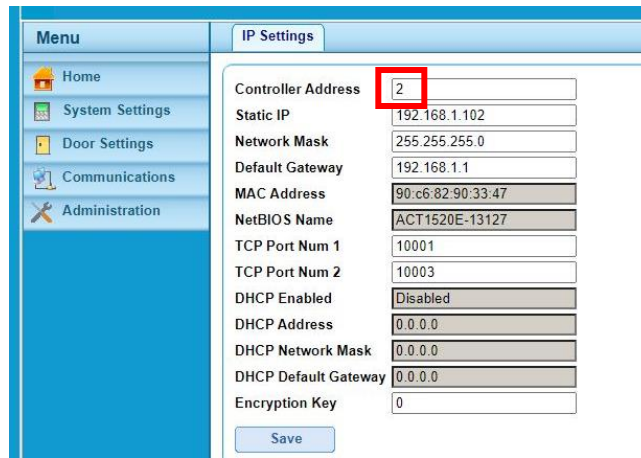

Figure 9

In ACTpro, navigate to the Communications tab of the slave controller, select 'Hubbed to Controller' and then pick the controller wired as the Master/Hub from the Drop Down list. In this case the controller with the name '1 - Master/hub' should be selected. Click Save.

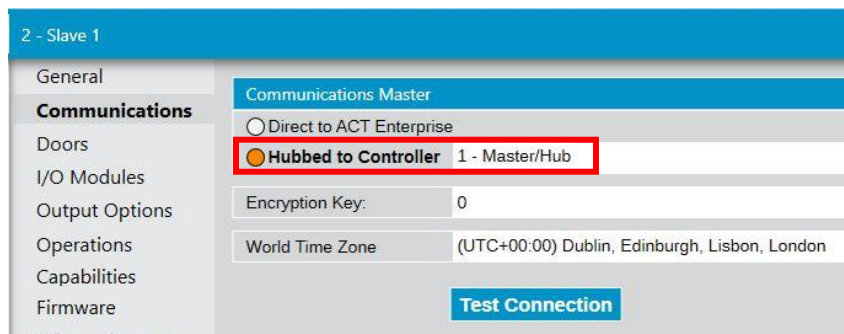
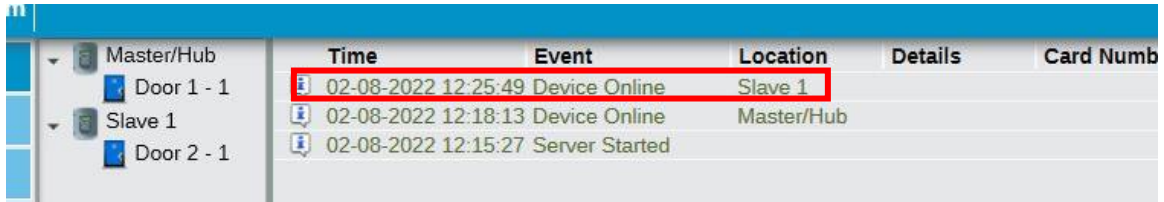

Figure 10

Slave 1 (Controller 2) ACTpro1520 is now online.

	No.	Controller Name	Controller type	Firmware	Comms	MAC address	Wiegand	Status
<input type="checkbox"/>	1	Master/Hub	ACT 1520e	01.11.10	192.168.1.101	90-C6-82-90-31-1	Default	
<input type="checkbox"/>	2	Slave 1	ACT 1520e	1.10.35	--> Controller [1	90-C6-82-90-33-1	Default	



	Time	Event	Location	Details	Card Num
Master/Hub	02-08-2022 12:25:49	Device Online	Slave 1		
Door 1 - 1	02-08-2022 12:18:13	Device Online	Master/Hub		
Slave 1	02-08-2022 12:15:27	Server Started			
Door 2 - 1					

Figures 11 and 12

2.3. Slave 2

Slave 2 is an ACTpro4000, this controller type always needs to be assigned a unique address regardless of how it is connected to ACTpro.

As with a 1520 it must also match its controller number within ACTpro (see figure 8) and its address must be a higher number than the Master/Hub controller.

As can be seen in Figure 12, ACTpro has assigned Slave 2 as Controller number 3, this is because 3 is the next available address in the Database.

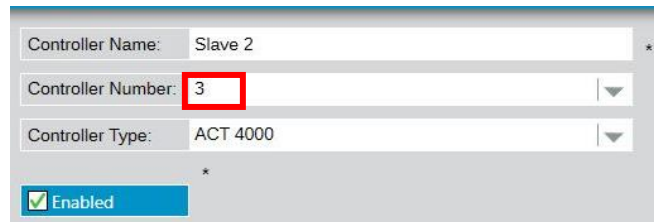

Figure 13

Slave 2 ACTpro4000 must now be given the unique address of 3. This has to be done using the keypad on the physical controller as follows:

Press: X - Engineer Code (Default = 999999) - 00✓✓ - Type the Required Address - ✓XX
So In this example Press: X99999900✓✓3✓XX

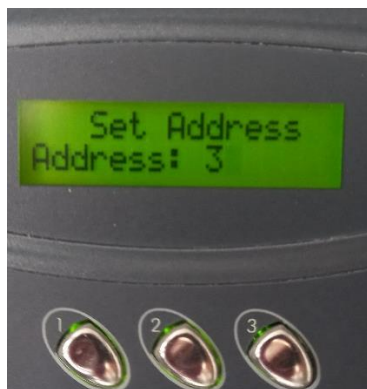

Figure 14

In ACTpro, navigate to the Communications tab, select 'Hubbed to Controller' and then pick the controller wired as the Master/Hub from the Drop Down list.

In this case the controller with the name '1 - Master/hub' should be selected.

Click Save.

Slave 2 (Controller 3) ACTpro4000 is now online.

No.	Controller Name	Controller type	Firmware	Comms	MAC address	Wiegand	Status	Doors	I/Os	Memory Card	Enabled
1	Master/Hub	ACT 1520e	01.11.10	192.168.1.101	90-C6-82-90-31-	Default		1 Doors			
2	Slave 1	ACT 1520e	1.10.35	--> Controller [1	90-C6-82-90-33-	Default		1 Doors			
3	Slave 2	ACT 4000	1.59	--> Controller [1	90-C6-82-90-33-	Default		2 Doors			

	Time	Event	Location	Details	Card
Master/Hub					
Door 1 - 1	02-08-2022 14:56:44	Menu Accessed	Slave 2	Installer	
Slave 1					
Door 2 - 1	02-08-2022 14:45:42	Menu Accessed	Slave 2	Installer	
Slave 2					
Door 3 - 1	02-08-2022 08:40:50	Device Powered Up	Slave 2		
Door 3 - 2	31-07-2022 13:12:17	Device Powered Up	Slave 2		
	30-07-2022 20:44:01	Device Powered Up	Slave 2		
	29-07-2022 08:41:01	Device Powered Up	Slave 2		
	28-07-2022 10:00:15	Device Powered Up	Slave 2		
	27-07-2022 08:59:32	Device Powered Up	Slave 2		
	26-07-2022 08:03:11	Device Powered Up	Slave 2		
	02-08-2022 15:02:29	Device Online	Slave 2		
	02-08-2022 14:24:04	Device Online	Slave 1		

Figures 15 and 16

If you have any questions, please contact our Technical Competence Centre.

Contact details can be found on our website.

ACRE international

www.vanderbiltindustries.com

www.comnet.net

TCC-2022-033_ACTpro_Controller_Hubbing_via_RS485_328_01_EN